

*Only Finally**

Jonathan Brennan

Abstract

Focus particles interact with the focused constituent in a sentence. The particle *only* presents a challenge to formalizing this relationship as while it commonly precedes the focused constituent, *only* can also follow it. A syntactic account of these constructions is presented that captures the unique properties of *only*'s distribution within the framework presented in Kayne (1998) and offers support for a finely articulated DP.

1 Introduction

This paper sets out to describe the syntactic properties of the focus particle *only* when the particle follows its focused associate (1), a construction that has been noted in descriptive grammars of English (2), but has not been addressed in the generative literature.

- (1) John spoke to one linguist *only*.
(2) This is for your eyes *only*. (Huddleston and Pullum, 2002, p. 590)

I will call the configuration in which *only* follows the constituent which receives focus ‘final *only*’. Adopting the framework presented in Kayne (1998), I suggest first that final *only* is structurally distinct from configurations in which *only* precedes a focused constituent (‘initial *only*’), and, second, that the syntactic and semantic properties of final *only* can be captured by appealing to a more finely articulated DP (Aboh, 2004).

Kayne (1998) offers an analysis of focus particles such as *only* that captures scope effects strictly in terms of movement in the overt syntax. As a component of this analysis, Kayne suggests a derivation for a sentence such as (3), where *only* precedes the focused element, according to the steps illustrated in (4) and (5).

- (3) John spoke *only* to Bill.

*For valuable feedback I am grateful to Chris Barker, Oana Săvescu Ciucivara, Chris Collins, Richard Kayne, Lisa Levinson, Tom Leu, Laura Rimell, Cara Shousterman, Anna Szabolcsi, Eytan Zweig, audiences at NELS37 and the 2007 meeting of the LSA, and two anonymous reviewers. The usual disclaimers apply.

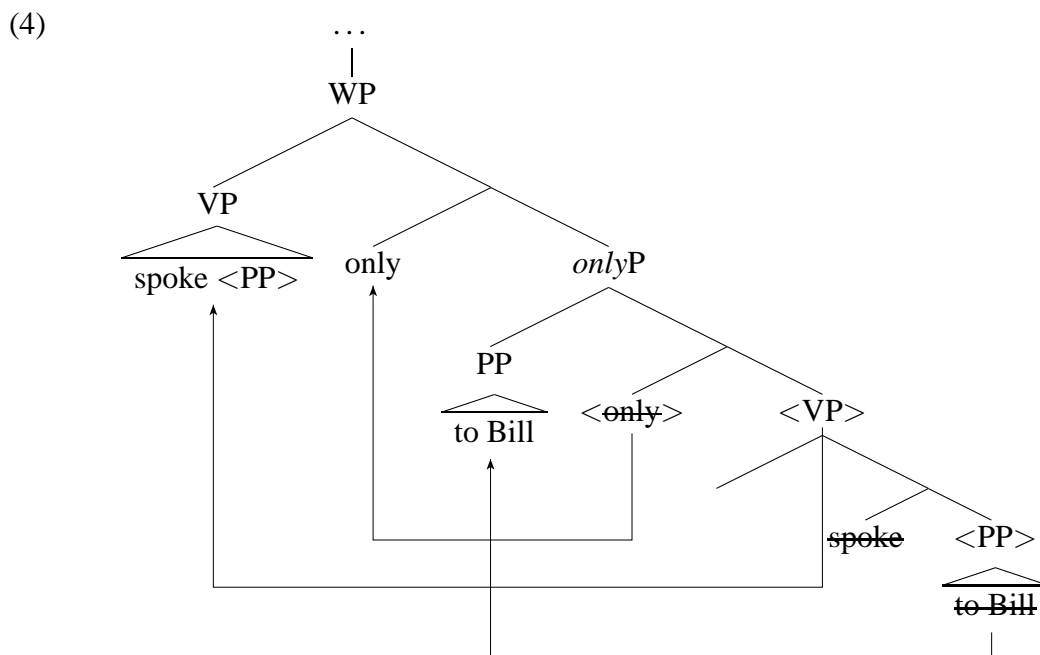

- (5)
- i. The PP *to Bill* is attracted to the specifier of VP-external *only*.
 - ii. *Only* raises further to an immediately higher head (called W).
 - iii. The remnant VP preposes to Spec,W.

Without addressing at present the arguments behind this kind of derivation¹, note a consequence of this analysis when extended to cover focus particles that have a different surface position. Kayne observes that particles such as *too* differ from *only* in that *too* follows the constituent under focus.

- (6)
- a. John gave Bill a book, *too*.
 - b. **Too* John gave Bill a book.

This observation can easily be accounted for by saying that *too*, unlike initial *only*, does not raise past its specifier into the immediately higher head position (W) but instead remains *in situ*.

Absent from previous literature on focus particles is the observation that *only* can also follow its focused associate.

- (7)
- a. John spoke *only* to one linguist.
 - b. John spoke to one linguist *only*.

Considering Kayne's treatment of *too*, one might suppose that *only* raises into W optionally, and its appearance to the right of the focused constituent follows when it remains *in situ* much like its counterpart. Such optionality is, in fact, invoked by Kayne to explain the positions in which the particle *even* can appear in, noting the following pair (his (134) and (135)).²

¹See McCloskey (1999) for a challenge to Kayne's approach, and Kayne (2000) for a reply.

²An anonymous reviewer points out that (8a,b) differ in his or her dialect of English with respect to where focus is permitted. Focus must be placed on *John* in (8b), and on *yesterday* in (8b), though the latter seems more flexible. This suggests to me that, for the reviewer though apparently not for Kayne, initial *even* is unable to take scope over IP. See §3.1 for similar observations concerning *only*.

- (8) a. John gave Bill a book yesterday, even.
 b. Even John gave Bill a book yesterday.

An analysis whereby the placement of *only* is effected by the same mechanisms underlying *too* and *even* predicts that the scope properties of sentence-final *only* and sentence-final *too* should be the same. It is remarkable, then, that the focus possibilities of the two sentence-final particles are not parallel.³

- (9) a. John spoke to [one linguist]_F, too.
 b. John_F spoke to one linguist, too.
 (10) a. John spoke to [one linguist]_F, only.
 b. ?? John_F spoke to one linguist, only.

This asymmetry suggests that the analysis in which *only* can optionally remain *in situ* is not as straightforward as it might appear at first. This paper presents a solution in which the properties of final *only* emerge from the availability in certain circumstances of a projection at the left periphery of DP which is headed by *only*. It is the specifier of this lower projection that is the landing site of the focused constituent when *only* appears finally.

2 Syntactic and Semantic Background

Before introducing Kayne's framework in more detail, some general comments about *only* are in order. *Only* has a truth-conditional effect when it has a focused element within its scope.

- (11) a. John only introduced Bill_F to Sue.
 b. John only introduced Bill to Sue_F.

(11a) and (11b) assert two semantically distinct propositions. In (11a) there is no person other than Bill who John introduced to Sue. In contrast, (11b) asserts that there is no person other than Sue to whom Bill was introduced by John. Rooth (1992, 1996) provides a semantic analysis within the alternative semantics theory for focus interpretation. The gist of his proposal is that putting focus on an element makes salient all of the (contextually relevant) alternatives to that element. *Only* is a quantifier which takes as an argument a clause with a focused element and asserts that replacing the focused element with one of its alternatives will not return a clause that is both distinct and true. Throughout this paper I will refer to the focused element in the scope of *only* as its 'focus associate'.

The capacity of a word to be the focus associate of *only* is contingent on it being in the syntactic domain of that particle, so focus can serve as a diagnostic for *only*'s domain. Following Kayne, amongst others, I adopt the assumption that the syntactic domain of *only* is defined over

³Notation in which multiple constituents are marked with a subscript *F* indicates elements which can optionally be given focus.

c-command; (12) illustrates the infelicity of focus outside of *only*'s c-command domain.^{4,5}

- (12) a. John introduced Bill only to [one linguist]_F.
 b. ?? John_F introduced Bill only to one linguist.

Note also that *only* can associate with a focused element that is a sub-part of its domain:

- (13) a. John only [introduced Bill to [Mary]_F].
 b. John only [introduced [Bill]_F to [Mary]].

Much of the present paper will be concerned with precisely defining the syntactic domain for *only* when it appears finally, for which the capacity to associate with focus will prove a primary diagnostic. Before turning to this topic some attention will be given to Kayne's (1998) account of the syntax of focus particles.

2.1 Kayne's Proposal: *Only* and Overt Scope

Kayne (1998) explores whether an account of scope facts for negation, focus particles, and a host of other scope-bearing elements can be accounted for strictly in terms of overt syntactic movement. It will suffice at present to sketch the consequences of his proposal as it relates to focus particles.

The derivation described in (4-5) forms the core of the proposal for which the basic tenet is that the constituent containing the focus associate has raised under the influence of a VP-external attractor, but this relationship has been masked by further syntactic movement. Kayne notes that alongside sentences such as (3) are sentences in which *only* intervenes between a preposition and its NP complement (14), however, in such cases there is a significant amount of speaker variation with regards to acceptability.

- (14) ? John spoke to only Bill

Kayne links the speaker variation of this example with limitations on preposition stranding in English.⁶ Preposition stranding results during the course of the derivation of (14) when the DP *Bill* raises under the influence of *only* out of the VP to Spec,*Only*P. This is illustrated in (15).

⁴Corrective, or contrastive, focus can be forced onto any element given enough prosodic emphasis and contextual salience, thus (i) is acceptable as a correction:

- i. No, JOHN saw only one linguist at the party.

I take this kind of focus interpretation to be irrelevant for the present data; see É Kiss (1998) for some discussion.

⁵More specifically, the syntactic domain consists of the constituents that can raise into the specifier of *only*, as illustrated in (4), which is defined over asymmetric c-command (Kayne, 1994).

⁶While English permits preposition stranding freely for constructions such as *wh*-extraction, heavy noun phrases that appear to the right of an adverbial PP ("Heavy NP shift") are significantly degraded.

- i. ?? John spoke to yesterday the man he met at the conference last summer.

(15)

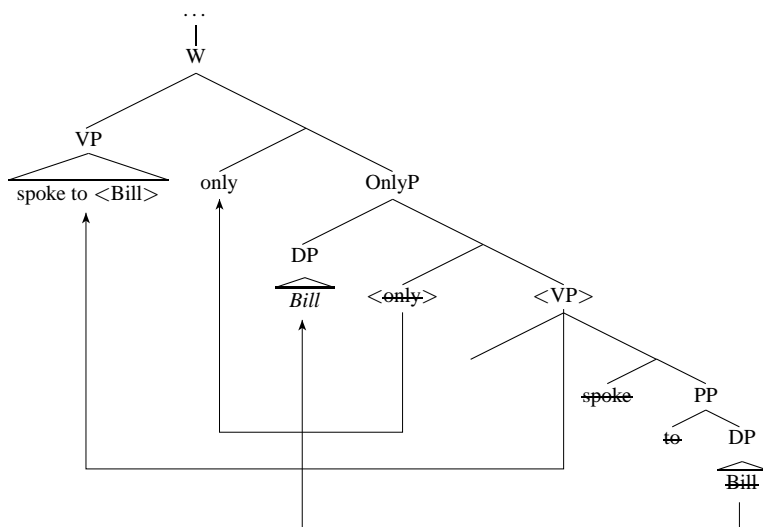

In comparison to (14), when *only* immediately precedes a quantified DP the sentence is fully acceptable (16).

(16) John spoke to only one linguist

In order to account for the contrast in acceptability between (16) and (14) Kayne proposes that whereas *only* does not combine directly with *Bill*, it does combine directly with the quantified DP *one linguist*. Just as *Bill* raises to the specifier of *only*, the constituent [*only one linguist*] raises to the specifier of a phonetically unrealized counterpart of *only* (labeled ONLY). To avoid preposition-stranding, the entire PP is pied-piped with *only* and the quantified NP.

(17)

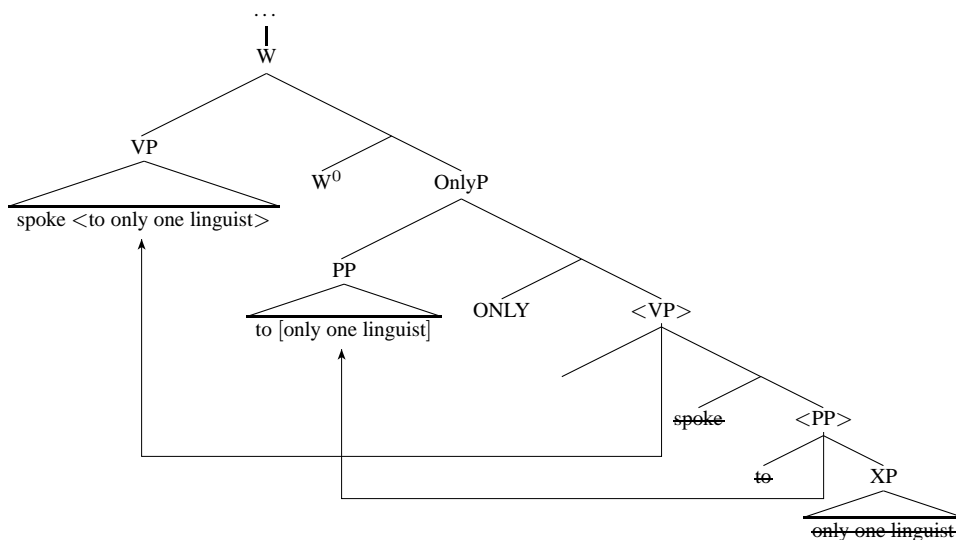

The two assumptions that Kayne adopts, that *only* forms a constituent with quantified DPs but not with non-quantified DPs, and that the constituent including *only* and a quantified DP can pied-pipe PPs but non-quantified DPs cannot, are used to account for the contrast between (14) and

(16) while maintaining the position that the scope of elements like *only* is established in the overt syntax, and thus involve attraction to a VP-external head. These assumptions permit a uniform derivation for scope-bearing elements, motivated by a wide range of data not reviewed here, at the expense of a single position for *only*.

The crucial aspect of Kayne's analysis for present purposes is that the asymmetry apparent when *only* adjacent to a DP which motivates the proposal that *only* can be base generated 'low' in the clause with DP under certain circumstances. In the next two sections it will be seen that this aspect of the proposal finds further support in the distribution of final *only*. It is important to note that the proposed constituency differences that motivate Kayne's claim will not themselves prove crucial for the present account. Furthermore, the proposal that *only* and a quantified DP raise together under the influence of a silent counterpart of *only* is not necessary to account for the basic distribution of final *only*. However, data will be reviewed in §5 which does offer some empirical support for this sort of movement which Kayne motivates primarily on theoretical grounds.

Having fleshed out some of the machinery Kayne uses to account for the properties of *only* when it precedes its associate, I now turn to examining the characteristics of final *only*.

3 Distribution of final *only*

This section explores the unique characteristics of final *only*. It will be shown that final *only* has restricted scope possibilities such that it must associate with a preceding DP (or any sub-constituent thereof), and cannot associate with any larger constituent (PP, VP...). It will also be observed that final *only* does not allow the same interpretive possibilities as initial *only*. These differences motivate the proposal that final *only* is generated as a constituent with DP, the details of which will be fleshed out in §4.

3.1 Scope Restrictions

Notably, when *only* precedes its focused associate it can take scope over a variety of constituents including DPs, PPs, and VPs (18-21). When appearing finally, however, it associates only with a preceding DP, and not larger constituents (22-24).

- | | | | |
|------|----|--|-------------|
| (18) | a. | Tommy hides only under [the bed] _F . | (PP) |
| | b. | Tommy hides only under _F the bed. | |
| (19) | a. | John only read [one book] _F . | (VP) |
| | b. | John only read _F one book. | |
| (20) | a. | John only shows Mary [his work] _F . | (Dbl. Obj.) |
| | b. | John only shows Mary _F his work. | |
| (21) | a. | Mary has requested only that John read <i>Aspects</i> _F . | (CP) |
| | b. | Mary has requested only that John _F read <i>Aspects</i> . | |

(18-21) simply show that *only* is free to associate with focus on any sub-constituent that follows the particle. In the examples below, however, note that the ungrammaticality of each of the (b) sentences suggests that final *only* is more restricted.

- (22) a. Tommy hides under [the bed]_F only. (PP)
 b. * Tommy hides under_F the bed only.
- (23) a. John read [one book]_F only. (VP)
 b. * John read_F one book only.
- (24) a. John shows Mary [his work]_F only. (Dbl. Obj.)
 b. * John shows Mary_F his work only.
- (25) a. Mary has requested that John read *Aspects*_F only. (CP)
 b. * Mary has requested that John_F read *Aspects* only.

In each example (a PP, VP, double object, and CP respectively), the (a) sentence shows the capacity for final *only* to associate with an immediately preceding DP; the (b) examples show that final *only* cannot associate with a more distant element. As noted in the introduction, this limitation contrasts with the freedom of association available for the particle *too* (see (9-10)).

Sentences with more complex DPs reveal that *only* can associate with a variety of elements within the DP.

- (26) a. John invited only [_{DP} [the student]_(F) from the [introductory course]_(F)].
 b. John invited [_{DP} [the student]_(F) from the [introductory course]_(F)], only.

The same can also be shown with adjectives.⁷

- (27) a. I want to work with a [_{DP} famous linguistics_F student] only.
 b. I want to work with a [_{DP} famous_F linguistics student] only.

The freedom for *only* to associate with any sub-constituent of the object DP strongly suggests that it is combining with the DP, and not just the immediately preceding minimal XP.

If final *only* could associate with any immediately preceding constituent, irrespective of phrasal category, than it should felicitously combine with an intransitive VP. Unergative clauses, however, are degraded when *only* appears finally (28).

- (28) a. John only walked.
 b. ?? John walked, only.

The marginality of (28b) contrasts starkly with examples above where *only* follows a DP, thus supporting the claim that final *only* can associate with a DP but no other phrasal category.

Thus far, examples have focused on *only* appearing sentence-finally. Turning to subjects, when *only* appears sentence-initially it can only associate with the subject DP but not with any elements lower in the clause. This restriction, noted by Kayne (amongst others) is taken to indicate that *only* cannot take scope over IP (29a).

- (29) a. Only [one linguist]_F came to the party.
 b. ?? Only [one linguist] came to [the party]_F.

Below, (30) shows that *only* can follow the subject as well.⁸

⁷I thank Chris Barker for pointing out these examples.

⁸The grammaticality of subject-final *only* appears influenced by whether or not the subject DP is a proper name (i-ii). This contrast parallels the asymmetry noted between (14) and (16).

- (30) [One linguist]_F only came to the party.
 (31) Passengers only are permitted on the platform. (Amtrack station, Lancaster PA)

In a simple example such as (30), the surface position of *only* is ambiguous between structural association with the subject or with the verb phrase. These two positions can be distinguished by inserting an auxiliary.⁹

- (32) a. [One linguist]_F only will walk across the Brooklyn Bridge.
 b. One linguist will only walked_(F) across_(F) [the Brooklyn Bridge]_(F).

In (32a) the adverb intervenes between the focus particle and the VP disambiguating the position of the particle as a subject modifier. The interpretation of (32a) clearly contrasts with that of (32b) by asserting that there is only one linguist that walked across the Brooklyn Bridge, and not that there exists some linguist who walked but did not run or bike across the bridge. Accordingly, it is clear that final *only* is not limited to sentence-final position

The observations thus far lead to the conclusion that final *only* is limited with respect to the focused constituent it may associate with according to the generalization in (33).

- (33) *Scope Generalization*
 Final *only* associates with focus on the immediately preceding DP.

3.2 Interpretive Differences

In addition to the scope restrictions observed above, there is a rather striking, if subtle, semantic difference between non-final and final *only*. Bayer (1996) notes that *only* can induce both a quantitative and a scalar interpretation of its focus associate:

- (34) a. SCALAR: John is only a waiter (but some day he might be head chef!)
 b. QUANT: John is only a waiter (he doesn't also act on the side.)

Bayer characterizes the different readings in terms of the range which constrain the set of alternatives activated by focus. Specifically, Bayer argues that the scalar reading relates to the set of alternatives associated directly with the DP *a waiter*, while the quantitative reading relies on the set of alternatives characterized by the things *x* that John might be.¹⁰

Interestingly, the scalar reading disappears when *only* appears after the focus associate; whereas (35a) is ambiguous, (35b) is not.

- (35) a. John is only a waiter.
 b. John is a waiter, only.

-
- i. One linguist_F only came to the party.
 ii. ? John_F only came to the party.

⁹I thank an anonymous reviewer for suggesting the use of auxiliaries to help disambiguate these sentences.

¹⁰Bayer (1996) further argues that the difference arising when *only* combines with a quantified NP, compared with a non-quantified NP, is due to the capacity for the quantifier to call up an appropriate range of alternatives for *only* to interact with. When combining with a non-quantified NP, the set of alternatives must be derived from the verb phrase, which in his analysis requires covert quantifier raising.

The pattern is summarized in (36).

(36)		Scalar	Quantitative
	Initial <i>only</i>	✓	✓
	Final <i>only</i>	*	✓

These facts, suggest that there is a non-trivial difference between final and non-final ordering even when limiting the comparison just to instances where *only* combines with a DP.

3.3 Interim Summary

Examining the properties of final *only* has revealed two striking differences between initial *only* and final *only*. First, it was observed that final *only* associates only with an immediately preceding DP. Second, it was observed that final *only* allows a more limited range of interpretations than initial *only*. In the next section an account is proposed which reduces these differences to a single structural difference between initial and final *only*.

4 Proposal: *only* and the left-periphery of DP

The properties of final *only* discussed above can be captured by expanding upon Kayne's proposal that in certain circumstances *only* forms a constituent with DP (see §2.1), a configuration I will call 'low' *only*.

Assuming that *only* also heads a projection when it is a constituent with the DP, just as it does when VP-external, it follows that this projection makes a specifier position available into which focused DP material may raise. I propose that this specifier position is the landing site of the focused DP when *only* appears finally. Crucially, the fact that *only* follows the focused constituent when generated in this low position indicates that there is no equivalent to the W projection to force the focus particle to raise past, and therefore precede, its own specifier; low *only* must remain in situ.¹¹

The proposed derivation is shown below in which final *only* is projected low in the clause in the left periphery of DP.¹² Note that I maintain Kayne's assumption that DP+*only* still raises to a VP-external projection headed by a silent counterpart of *only*.

¹¹The intuition here is that the absence of W might correlate with other structural differences between DP and IP, perhaps the availability of Agr (cf. Kayne, 2002, w.r.t. W and Agr), though this line of thought is not further pursued here. I thank an anonymous reviewer for helping to clarify this point.

¹²Further evidence that final *only* is merged above D⁰ comes from the interpretation of final *only* when used in signs.

- i. *Exit only* = Only the exit (not an entrance)
 ≠ The only exit (no other exits)

Holding *the* to be merged as D⁰ (Abney, 1987), these data show that final *only* is interpreted the same as when *only* precedes *the*. Interestingly, this conclusion is incompatible with identifying *only*P with Aboh's (2004) focP which is necessarily merged beneath the definite determiner.

(37)

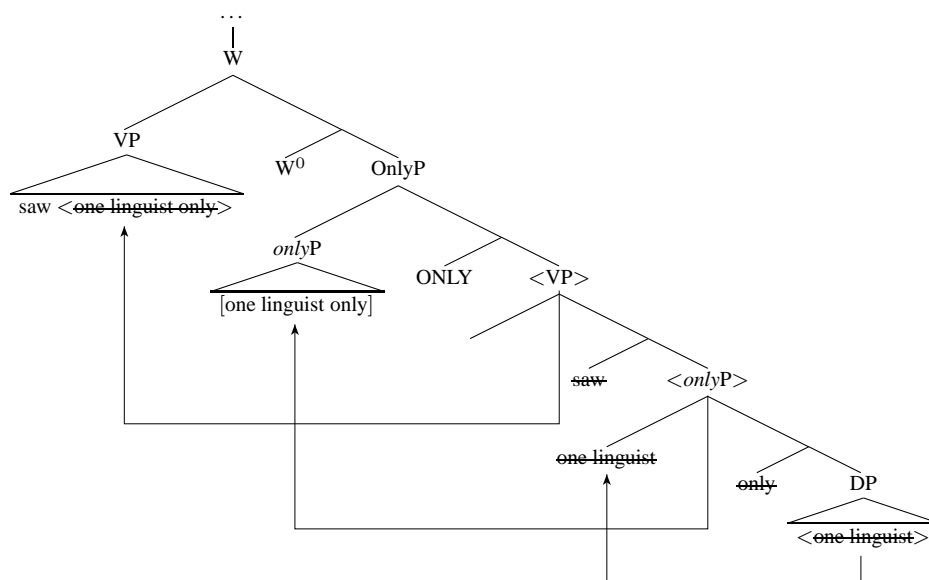

- (38) i. The DP *one linguist* is attracted to the specifier of DP-external *only*.
- ii. *OnlyP* raises to the specifier of an unpronounced VP-external attractor.
- iii. The remnant VP preposes to Spec,W.

The proposal accounts for the scope facts in (22-25) straightforwardly as the option for a focused element to precede *only* is limited to the DP; the W head always forces a VP-external *only* to raise past its specifier, so the configuration where the focused element precedes the particle *only* obtains in the DP.¹³ Interestingly, if this approach is on the right track, then the availability of final *only* with proper names, as in (39), provides some evidence against Kayne’s claim that *only* is unable to form a constituent with a non-quantified DP, as it is just when *only* is a constituent with DP that final *only* is possible.

(39) John read *Aspects* only.

The interpretive differences summarized in (36) follow from this account as well by noting Barbiers’ (1995) observation that scalar interpretation requires *only* to immediately c-command the surface position of the focused associate.¹⁴ The contrast shown between (40a,b) shows that scalar interpretation is unavailable when material intervenes between initial *only* and the focused constituent, interrupting immediate c-command. (40b) is only compatible with a reading in which John hates that his only job is waiting tables.

¹³Note that the implication does not operate in the other direction as well, that is, low *only* does not force the DP to raise into its specifier. This must hold in order to maintain Kayne’s analysis of the asymmetry between [*only Bill*] and [*only one linguist*] in which the latter, but not the former, forms a constituent. Consequently, the present proposal must accept the possibility that syntactic movement can be optional.

¹⁴From Barbiers (1995, p. 27):

- i. X immediately c-commands Y iff
 - a. X c-commands Y and
 - b. There is no closer c-commander W such that X c-commands W and W c-commands Y

- (40) a. John hates being only a waiter_F (quant. / scalar)
 b. John hates only being a waiter_F (quant. / *scalar)

When a focused constituent lands in the specifier of *only* than it is no longer c-commanded by that head, thus ruling out scalar interpretation.¹⁵ In other words, the interpretive restriction on final *only* follows from the structural configuration.

A question raised by this structural proposal is whether low *only* differs from high *only* is with respect to the quantificational domain in which it is interpreted. A primary motivation for Kayne's VP-external *only* the possibility of a wide scope interpretation in bi-clausal constructions (41) (Kayne's (68)).

- (41) She has requested that he read only *Aspects*

(41) is felicitous with the interpretation that there is only one request made, that is, *only* can take scope in the matrix clause. Interestingly, wide-scope interpretation is not possible with final *only*.

- (42) She has requested that he read *Aspects* only.

(42) is only compatible with an interpretation in which *Aspects*, but nothing else, must be read. This suggests that *only* must be interpreted within the embedded clause. However, there are a variety of other configurations that disrupt the possibility of wide-scope interpretation which make this observation difficult to interpret.

- (43) a. Mary requested that John read only articles.
 b. A teacher requested that John read only *Aspects*.
 c. Mary requested that a student read only *Aspects*.
 d. Mary requested that John read only *Aspects* before going to bed.

The examples in (43) all allow only a low scope reading for *only*, showing that wide scope interpretation is not only sensitive to the structural position of *only*, but also to the plurality of the object (43a), the presence of other quantifiers in the sentence (43b,c), or the presence of a VP adjunct (43d). Final *only* is one of a variety of configurations that interrupts the capacity for the focus particle to scope over the matrix clause.

If the unavailability of wide-scope interpretation with final *only* indeed follows from a pattern orthogonal to the present structural proposal what can be said regarding the contribution of low *only*? One possible answer follows Lee's (2004) analysis of focus particles in Korean in which it is argued that the interaction between *only* and other quantifiers reveals that regardless of where the focusing particle is spelled out, it takes scope at a fixed position in the clause. Lee concluded that the Korean focus particle traditionally glossed as *only* might be better conceived of as an agreement marker that is checked by movement to a VP-external projection headed by a silent counterpart of *only*. This approach is appealing, though it remains to be seen whether it can be adequately extended to English.

¹⁵Of course, the restriction on scalar interpretation remains a descriptive phenomenon itself in need of explanation.

In sum, I propose that the configuration in which *only* follows the focused associate amounts to the base generation of *only* in a position immediately dominating the DP followed by the (optional) movement of DP to the specifier of *only*.¹⁶ The relationship between the focus particle and the clause containing the focus associate is established via a Spec-Head configuration. This configuration is consistent with proposals that DP hosts an articulated left periphery, similar to the clausal left periphery (Rizzi, 1997), that hosts discourse related projections (Ntelitheos, 2002; Aboh, 2004).

5 Further Predictions: Particles and Possessives

In order to remain as close to Kayne's proposal as possible, the derivation in (37) includes a movement step where the constituent [*only one linguist*] raises to a VP-external projection containing an unpronounced head. If such a movement step does in fact obtain, then it should show evidence of being blocked by standard limitations on syntactic movement. The following section shows that limitations on the possibility of final *only* with possessives and with particles demonstrate exactly the predicted pattern.

Final *only* is not able to directly follow a possessor DP (44).¹⁷

- (44) a. * John saw one linguist_F only's hat.
 b. John saw only one linguist_(F)'s hat_(F).

Furthermore, final *only* is also impossible in verb particle constructions when the object intervenes between the verbal particle and the verb. In contrast, initial *only* is acceptable irrespective of the placement of the particle (46).

- (45) a. * John called [one linguist_F only] up.
 b. John called up [one linguist_F only].
 (46) a. John called only one linguist_F up.
 b. John called up only one linguist_F

Adopting a small clause analysis of verb-particle constructions (e.g. Kayne, 1985; den Dikken, 1995), these data can be seen to both be instances where final *only* is not permissible within a left branch.

A unified account of these restrictions can be given by linking the ungrammaticality of final *only* with the restriction on sub-extraction out of a left branch (Ross, 1967).

- (47) * Who did they find [[the brother of *t*]'s hat]? (possessive)

¹⁶An anonymous reviewer points out that, as illustrated in (37), movement into Spec,*only*P amounts to movement from the complement of a head into the specifier of that head which is argued to be unavailable by (Abels, 2003) amongst others. Note, however, that if the left-periphery of DP is as finely articulated as it is for the clausal domain (as in, e.g., Aboh, 2004), then the tree shown in (37) might be expanded to include some number of projections intervening between *only*P and DP (perhaps TopicP).

¹⁷Note that there is no general restriction on complex DPs in possessor position.

- i. John saw the man with the red hat's wife.

- (48) * Who did they call [[the brother of *t*] up]? (particle verb)

(47-48) show that both possessive and verb-particles do not permit sub-extraction of a constituent out of a left branch. I propose that the same restriction is responsible for the ungrammaticality of final *only* observed in (44a) and (45a). This follows from the account already proposed because of the requirement that low *only* must raise into the specifier of the VP-external silent counterpart of *only*. The only additional condition necessary is that low *only* must be unable to pied-pipe the entire possessive DP or the small clause headed by the verbal particle. Thus it is concluded that low *only* can pied pipe projections from complement position (see (17)), but not from a specifier. The illicit derivations are illustrated below for possessives (49a) and verbal particles (49b).

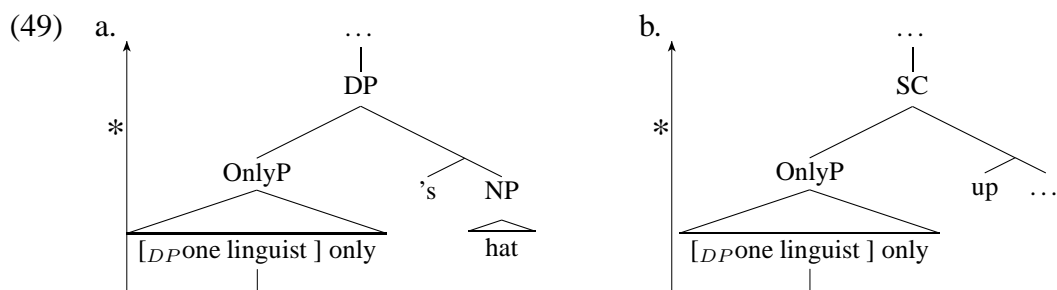

The acceptability of (44b) follows from a derivation in which the entire possessive DP, [*one linguist's hat*] in (44b), raises together to the specifier of VP-external *only*. Similarly, the acceptability of (46a) follows from a derivation in which the constituent [_{SC} *one linguist up*] raises to the specifier of VP-external *only*.

A question emerging from this analysis concerns the pied-piping limitations of low *only*. The restriction on final *only* in possessives and before verbal particles is argued to follow from the left-branch condition on extraction, however, such an argument requires that *only*, unlike *wh*- phrases, cannot pied pipe a projection from the specifier position as an alternative to the disallowed extraction. On the other hand, *only*P can pied-pipe from complement position (17).¹⁸ One possible avenue to explore would be whether this asymmetry could be derived by an account of pied-piping by feature percolation and cyclic Spec-Head agreement suggested by Koopman and Szabolsci (2000), amongst others. In the present analysis this would reduce to the possibility that low *only* checks focus features, eliminating the capacity for a focused element to be a pied-piper.

6 Conclusion

Final *only* has been observed to have distinct properties from its initial counterpart. These properties have been captured by proposing that *only* can head a projection in the left-periphery of the DP which hosts a specifier into which the focused material raises. Further data from the ungrammaticality of final *only* in possessives and before verbal particles supports the proposal that low *only*P must itself raise to the specifier of a VP-external projection hosted by a silent counterpart of *only*.

More broadly, the present analysis supports proposals that DP has an articulated left-periphery which is capable of hosting discourse related particles (Aboh, 2004; Ntelitheos, 2002), and pro-

¹⁸Note that the pied-piping opportunities of *only* phrases appears to be opposite that observed for *wh*-questions across Germanic languages for which the specifier is the canonical pied-piping position (Webelhuth, 1992).

vides further evidence that the relationship between focus and focus particles is mediated by a Spec-Head configuration established in the overt syntax.

References

- Abels, Klaus. 2003. Successive cyclicity, anti-locality, and adposition stranding. Doctoral Dissertation, University of Connecticut.
- Abney, Steven. 1987. The English noun phrase in its sentential aspect. Doctoral Dissertation, Massachusetts Institute of Technology.
- Aboh, Enoch O. 2004. Topic and focus within D. *Linguistics in the Netherlands 2004* 21:1–12.
- Barbiers, Sjef. 1995. *The syntax of interpretation*. The Hague: HAG.
- Bayer, Josef. 1996. *Directionality and logical form: On the scope of focusing particles and wh-in-situ*. Dordrecht: Kluwer.
- den Dikken, Marcel. 1995. *Particles: On the syntax of verb-particle, triadic, and causative constructions*. Oxford: Oxford University Press.
- É Kiss, Katalin. 1998. Identificational focus and informational focus. *Language* 74:245–273.
- Huddleston, Rodney, and Geoffrey K. Pullum. 2002. *The Cambridge grammar of the English language*. Cambridge: Cambridge University Press.
- Kayne, Richard S. 1985. Principles of particle constructions. In *Grammatical representations*, ed. Jacqueline Guéron, Hans-Georg Obenauer, and Jean-Yves Pollock. Dordrecht: Foris.
- Kayne, Richard S. 1994. *The antisymmetry of syntax*. Linguistic Inquiry Monographs. Cambridge, MA: MIT Press.
- Kayne, Richard S. 1998. Overt vs. covert movement. *Syntax* 1:128–191.
- Kayne, Richard S. 2000. On the left edge in UG: A reply to McCloskey. *Syntax* 3:44–51.
- Kayne, Richard S. 2002. On some prepositions that look DP-internal: English *of* and French *de*. *Catalan Journal of Linguistics* 1:71–115. Ms. NYU.
- Koopman, Hilda, and Anna Szabolsci. 2000. *Verbal complexes*. Cambridge, MA: MIT Press.
- Lee, Youngjoo. 2004. The syntax and semantics of focus particles. Doctoral Dissertation, Massachusetts Institute of Technology.
- McCloskey, James. 1999. On the right edge in Irish. *Syntax* 2:189–209.
- Ntelitheos, Dimitris. 2002. Possessor extraction in Greek and the left periphery of DP. Ms. UCLA, March 2002.
- Rizzi, Luigi. 1997. The fine structure of the left periphery. In *Elements of grammar*, ed. L. Haegeman, 281–337. Dordrecht: Kluwer.
- Rooth, Mats. 1992. A theory of focus interpretation. *Natural Language Semantics* 1:75–116.
- Rooth, Mats. 1996. Focus. In *The handbook of contemporary semantic theory*, ed. Shalom Lappin, chapter 10. Blackwell.
- Ross, John R. 1967. Constraints on variables in syntax. Doctoral Dissertation, Massachusetts Institute of Technology.
- Webelhuth, Gert. 1992. *Principles and parameters of syntactic saturation*. New York: Oxford University Press.